

Spool Cap and Tension Brush Payoff

A simple, economical method of paying off many types of wire with steady back tension

Features

- Smooth, nickel plated steel cap
- Best with single bare wire, insulated wire, and some multiwire
- Speeds up to 600 feet per minute
- Easily mounted by attachment to the spool with a bore adapter
- Tension brushes are made from wear-resistant monofilament nylon, customized according to the wire type and size.
- Tension is maintained when payoff stops, so **no** “run on” or “cascading” occurs. This eliminates wire breaks at startup.
- Payoff can be vertical, horizontal or angled. Wyrepak offers payoff stands; examples include:

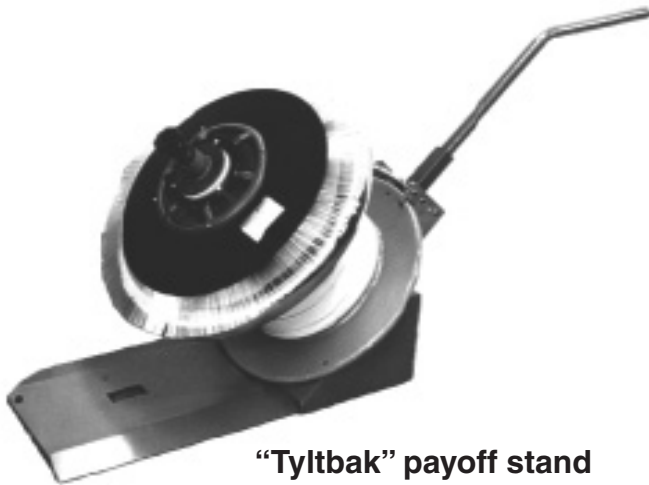
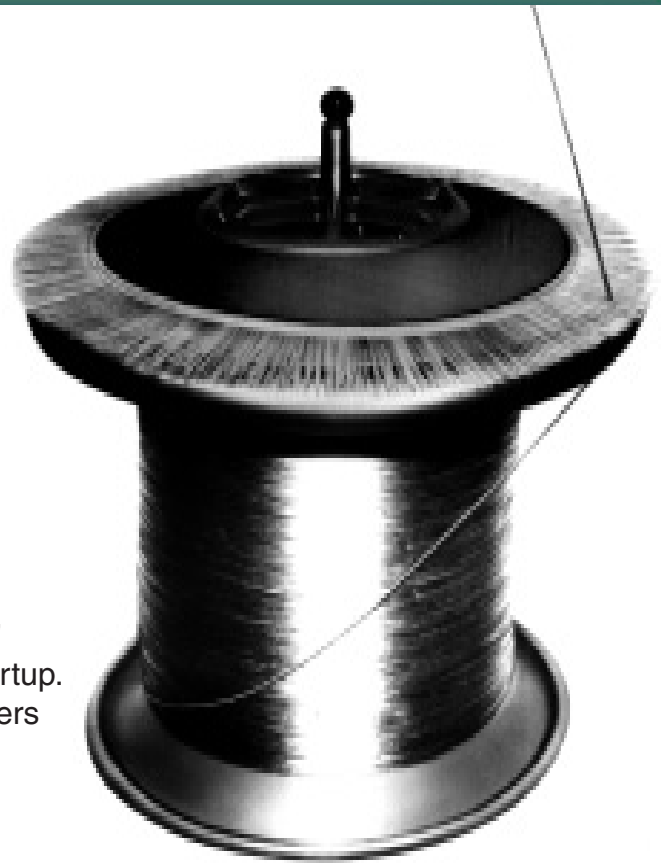

“Tyltbak” payoff stand

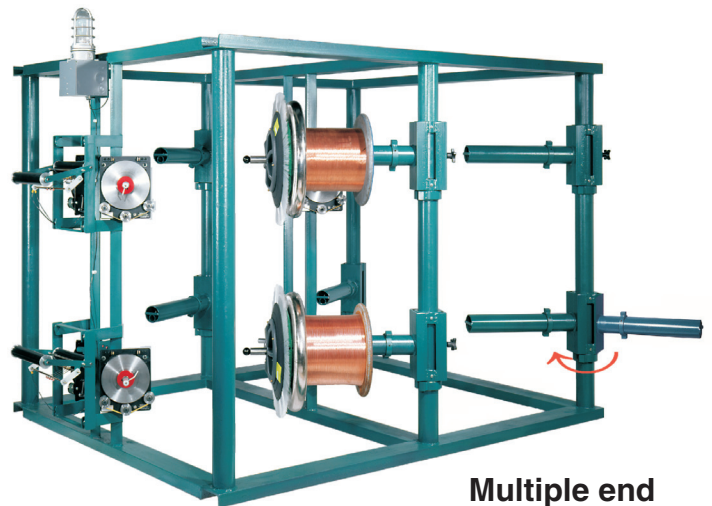

Multiple end payoff stand

- Reels from 6” (DIN 150) to 48” (DIN 1250) can be accommodated

WYREPAK INDUSTRIES

697 Middle Street, Middletown, CT 06457 USA
 Phone: 860-632-5477 • Fax: 860-632-5775
 e-mail: wyrepakdave@yahoo.com
 web: wyrepakind.com

OR
 CONTACT:

TD
 ENGINEERING LTD.

e-mail: sales@td-engineering.com
 UK Phone: +44 (0) 1509 239 832

FIGURE 1: WIRE CONTROL POINT

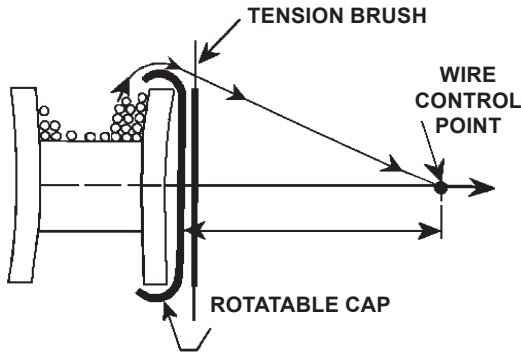

In this diagram of a cap-brush unit attached to a reel, payoff wire orbits the fixed brush. The tension brush holds orbiting wire in place for quick stops and starts. Wire diameter and speed determines tine diameter. Wire control point on any reel center is ideally 1 to 1.5 times the diameter of the reel away from the cap. The rotatable cap covers reel flange with proper clearance, acting as a "slippery flange". Rotation eliminates breaks and removes all material from reel.

**FIGURE 2: Rotatable cap, tension brush unit
6" thru 14" diameter (152-355 mm.)**

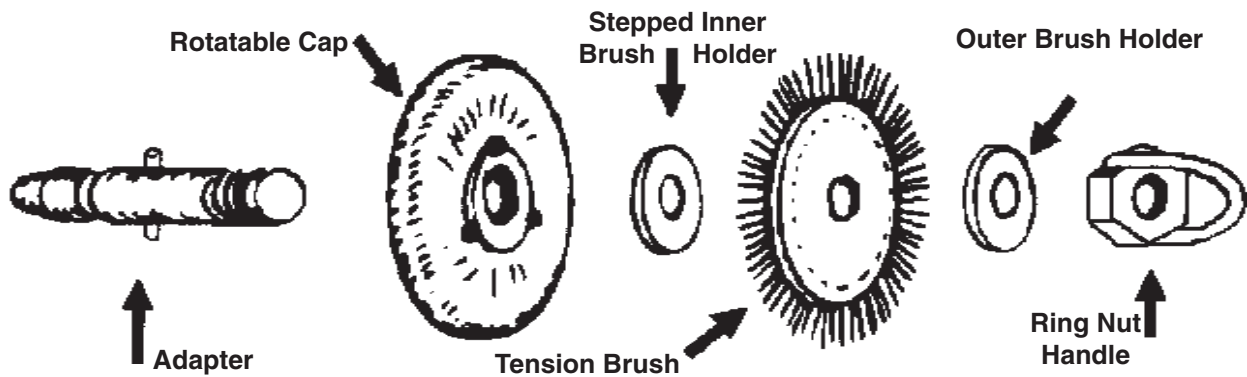

**FIGURE 3: Rotatable cap, tension brush unit
16" thru 49" diameter (406-1245 mm.)**

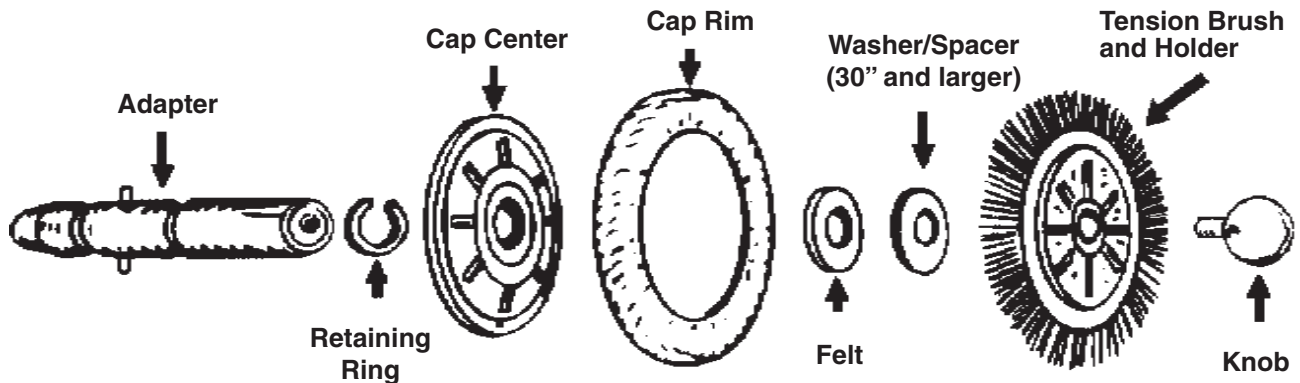

Data Sheet PD1 *continued*

TABLE 1

Wire sizes, speeds and brush tine diameters for rotatable-cap/tension brush units

Reel flange diameter (Cap-brush unit, nominal)		Tension brush tine diameter		Normal payoff speed		Wire size diameter	
in.	mm.	Standard tine ¹ in.	mm.	Approximate maximum ² Ft./min	m/min.	Usual practice in.	mm.
6	152	.006	.152	500	152	.002-.004	.051-.103
		.010	.254			.004-.005	.103-.127
		.014	.356			.005-.010	.127-.254
8	203	.010	.254	600	183	.004-.005	.103-.127
		.014	.356			.005-.010	.127-.254
		.018	.456			.010-.015	.254-.381
		.024	.585			.015-.035	.381-.890
10	254	.010	.254	600	183	.004-.005	.103-.127
		.014	.356			.005-.010	.127-.254
		.018	.456			.010-.015	.254-.381
		.024	.585			.015-.035	.381-.890
12	305	.014	.356	600	183	.010-.016	.254-.405
		.018	.456			.016-.020	.405-.508
		.024	.585			.020-.040	.508-1.03
14	355	.014	.356	600	183	.010-.020	.254-.508
		.018	.456			.020-.040	.508-1.03
		.024	.585			.040-.050	1.03-1.27
		.032	.812			.050-.064	1.27-1.63
16	406	.014	.356	600	183	.010-.020	.254-.508
		.018	.456			.020-.040	.508-1.03
		.024	.585			.040-.050	1.03-1.27
		.032	.812			.050-.064	1.27-1.63
17.5	445	.014	.356	600	183	.010-.020	.254-.508
		.018	.456			.020-.040	.508-1.03
		.024	.585			.040-.050	1.03-1.27
		.032	.812			.050-.064	1.27-1.83
22-22.5	559-572	.018	.456	600	183	.015-.030	.381-.762
		.024	.585			.030-.045	.762-1.14
		.032	.812			.045-.064	1.14-1.63
		.040	1.03			.064-1.00	1.63-2.54
24	610	.018	.456	600	183	.015-.030	.381-.762
		.024	.585			.030-.045	.762-1.14
		.032	.812			.045-.064	1.14-1.63
		.040	1.03			.064-1.00	1.63-2.54
28	711	.024	.585	600	183	.030-.045	.762-1.14
		.032	.812			.045-.064	1.14-1.63
		.040	1.03			.064-.110	1.63-2.79
		.060	1.52			.110-.130	2.79-3.30
30	762	.024	.585	600	183	.030-.045	.762-1.14
		.032	.812			.045-.064	1.14-1.63
		.040	1.03			.064-.110	1.63-2.79
		.060	1.52			.110-.130	2.79-3.30
32	800	.024	.585	600	183	.030-.045	.762-1.14
		.032	.812			.045-.064	1.14-1.63
		.040	1.03			.064-1.10	1.63-2.79
		.060	1.52			.110-.130	2.79-3.30

1) Tension brush standard tine diameters will satisfy most wire payoff conditions if other payoff variables are properly evaluated and corrected to optimum conditions. Special brushes can be made for special payoff situations.
 2) "Normal" operation is running speed just below maximum without domes or other wire constraining devices and with tension brush diameters slightly larger than rotatable cap diameters. First guide eye position is important to insure no "ballooning" and no excessive brush wear. Speeds listed may be exceeded by using WyrePak's rotatable cap/brush system.
 3) 36 inch and larger cap assemblies are supplied with cast aluminum machined centers for increased strength and stability.
 4) This table is for single strand bare copper wire. For insulated and steel wire heavier brushes may be needed. For aluminum wire a lighter brush may be required.



697 Middle Street, Middletown, CT 06457 USA
 Phone: 860-632-5477 • Fax: 860-632-5775
 e-mail: wyrepakdave@yahoo.com
 web: wyrepakind.com

OR CONTACT:



e-mail: sales@td-engineering.com
 UK Phone:+44 (0) 1509 239 832

TABLE 1

Wire sizes, speeds and brush tine diameters for rotatable-cap/tension brush units

Reel flange diameter (Cap-brush unit, nominal)		Tension brush tine diameter		Normal payoff speed		Wire size diameter	
in.	mm.	Standard tine ¹ in.	mm.	Approximate maximum ² Ft./min	m/min.	Usual practice in.	mm.
36	915	.024	.585	600	183	.030-.045	.762-1.14
		.032	.812			.045-.064	1.14-1.63
		.040	1.03			.064-.110	1.63-2.79
		.060	1.52			.110-.130	2.79-3.30
39 ³	990	.024	.585	600	183	.030-.045	.762-1.14
		.032	.812			.045-.064	1.14-1.63
		.040	1.03			.064-.110	1.63-2.79
49 ⁴	1245	.060	1.52	600	183	.110-.130	2.79-3.30

- 1) Tension brush standard tine diameters will satisfy most wire payoff conditions if other payoff variables are properly evaluated and corrected to optimum conditions. Special brushes can be made for special payoff situations.
- 2) 'Normal' operation is running speed just below maximum without domes or other wire constraining devices and with tension brush diameters slightly larger than rotatable cap diameters. First guide eye position is important to insure no "ballooning" and no excessive brush wear. Speeds listed may be exceeded by using WyrePak's rotatable cap/brush system.
- 3) 36 inch and larger cap assemblies are supplied with cast aluminum machined centers for increased strength and stability.
- 4) This table is for single strand bare copper wire. For insulated and steel wire heavier brushes may be needed. For aluminum wire a lighter brush may be required.

Higher Speed Units

Standard units allow payoff up to 600 feet/min (184 meters). Higher speeds of up to 1200 feet/min (370 meters) can be achieved by using WyrePak's PD26/FD26A units. The tension brush rotates initially at a slow speed and then faster as speed and tension increase when spools go from full to empty.

**FIGURE 4:
PD26A unit for 6" (200mm)
to 14" (350mm) spools**

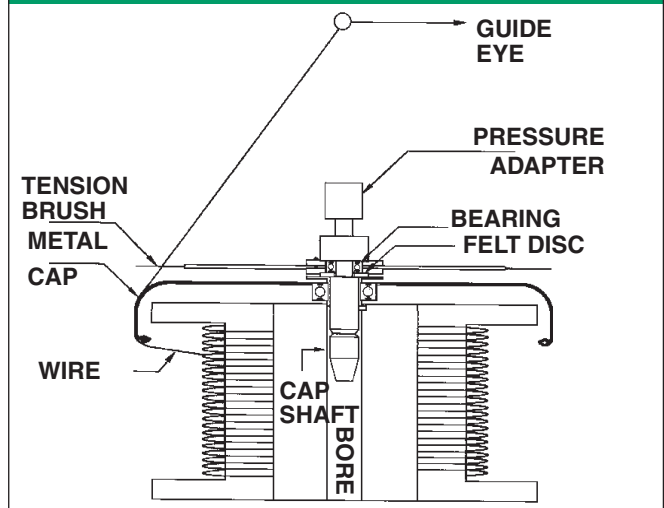

**FIGURE 5:
Composite of PD26 unit for 16" (406mm) to 49" (1245mm)**

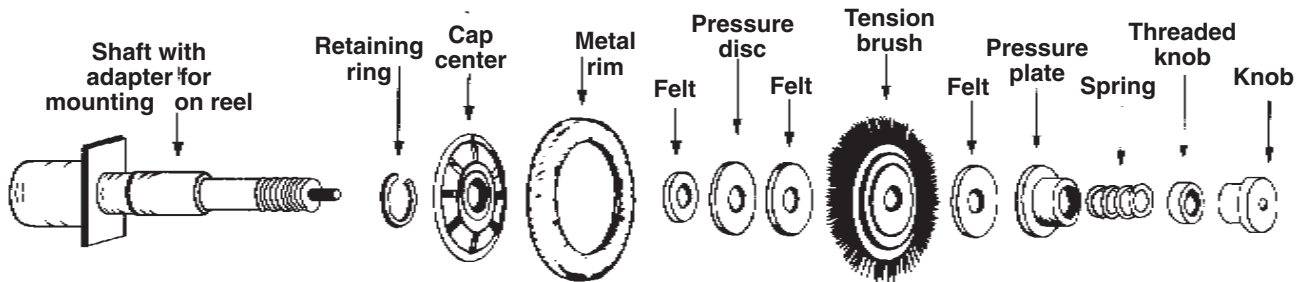

WYREPAK INDUSTRIES
 697 Middle Street, Middletown, CT 06457 USA
 Phone: 860-632-5477 • Fax: 860-632-5775
 e-mail: wyrepakdave@yahoo.com
 web: wyrepakind.com

OR
CONTACT:

TD ENGINEERING LTD.
 e-mail: sales@td-engineering.com
 UK Phone: +44 (0) 1509 239 832