

Driven Rolloff Payoff with Constant Tension

Wyrepak's driven payoff unrolls material without twist and with constant tension. The accumulator stores 3 to 4 meters of material, providing a smooth, controlled operation.

Ideal for most types of bare and insulated wire, including communication cables, special cables, on twinners, bunchers, and stranders. In fact, this unit handles almost any material which must be unrolled without twist.

- Pull and cut harness machines
- Pull and cut conduit inners and outers
- Extrusion lines

Wire range:

0.1 mm to 6 mm stranded or single end
Up to 12 mm special

Accumulator controlled D.C. driven reel

Standard running speed:
300 m (1000 ft) per minute

Standard tension range:
0.1 to 15 kilograms

For DIN 400 reel: Unit Ref. DRBP-8

For DIN 500 reel: Unit Ref. DRBP-10

For DIN 630 reel: Unit Ref. DRBP-12

Modified units are available for larger reels

Pintle method for each side of reel
available as an option

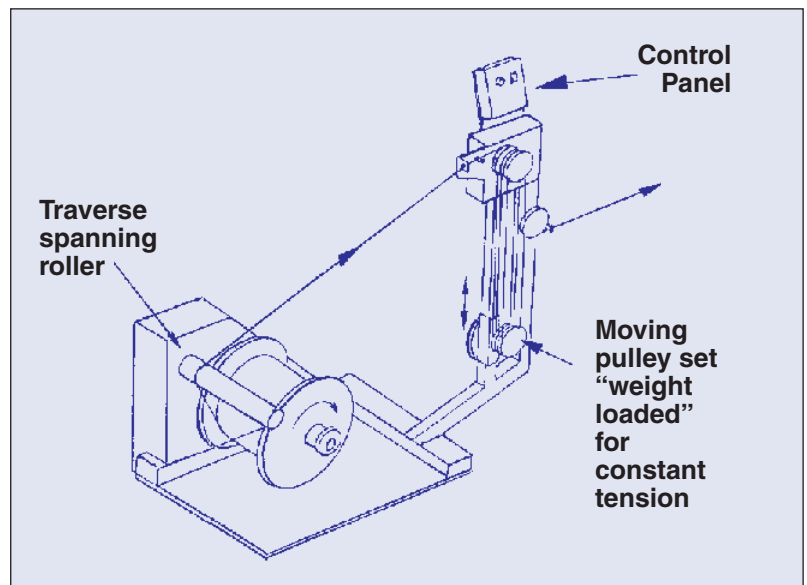
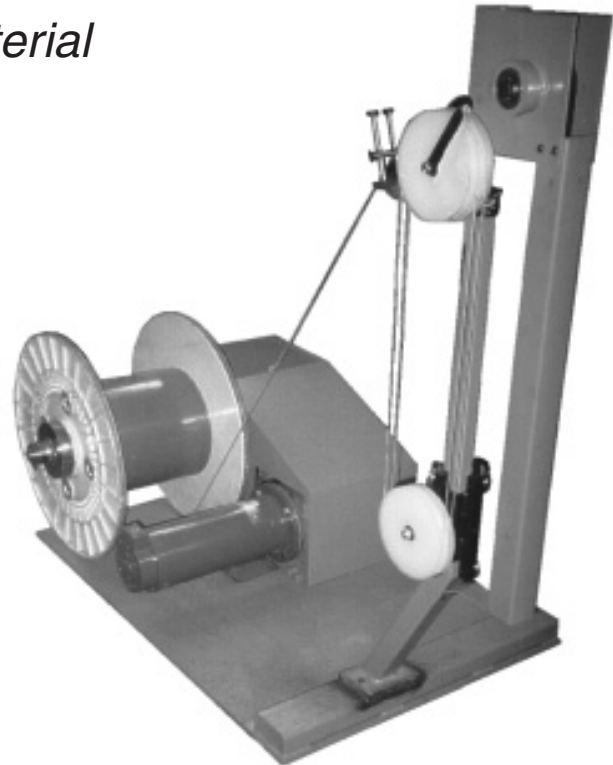

WYREPAK INDUSTRIES

697 Middle Street, Middletown, CT 06457 USA
Phone: 860-632-5477 • Fax: 860-632-5775
e-mail: wyrepakdave@yahoo.com
web: wyrepakind.com

OR
CONTACT:

TD
ENGINEERING LTD

e-mail: sales@td-engineering.com
UK Phone: +44 (0) 1509 239 832