

Flyer Arm Payoff Unit

TYPE BMPFT

This Flyer arm has been designed specifically to pay off multi wire, but works equally well with other types of bare or insulated material.

Features

- Full span leading traverse roller is bearing mounted to smoothly pull the multi ends or other type of material *outwards* from the spool.
- End flanges on the roller insure the wire path at traverse ends is controlled, and the payoff material cannot escape (particularly at speed or sudden stops).
- Clamping bore adapter locks the unit into the bore of the spool. This eliminates vibration and insures concentricity.
- The optional swivel top assembly allows payoff directly towards the process from the spool.
- The “Ferodo” friction disc braking unit provides smooth, constant tension at the level best for the application. It has low braking noise and a minimum “bedding-in” period. Improved wear characteristics give extended life expectancy.
- Optional adjustable arm length allows the unit to be used on different size spools.



Specifications

- Individual flyer arms are suitable for spools/reels with flanges from 16” to 40” (din 400-din 1000).
- Adjustable flyer arms are available for 16”-22” spools (din 400-din 560), 24” - 32” spools (din 630-din 800), 32”- 40” spools (din 800- din 1000).
- All flyer arms are dynamically balanced.
- Speeds up to 800 feet per minute with standard unit (din 630 are typical). Higher speeds up to 1500 feet per minute are achievable with vertical exit high speed flyers fitted with special traverse roller and other modifications.
- Wire or other material suitable for these flyer arms include:
 - Multi ends (all sizes)
 - Single bare copper 0.2-1.5 mm dia. (0.008”-0.064” dia.)
 - Insulated material up to 4 mm (0.16”) o/d.
- Small bunched or bare and insulated wire
- Large bunched or stranded bare or insulated material can be accommodated by increasing the traverse roll diameter. Installation is very simple- plug the unit into the top bore of the spool/reel, tighten the locking lever, and set the desired tension required by adjusting the spring loading on the circular brake disc using the knurled hand nut crank.

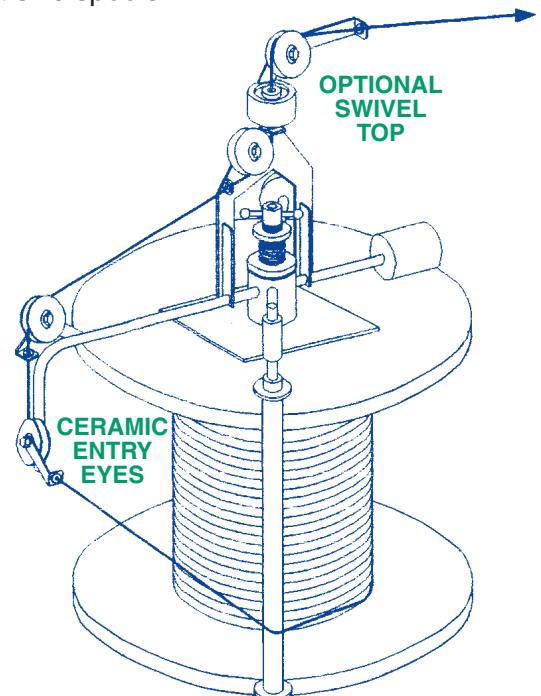

We offer this BMPFT unit with confidence, knowing it will pay off almost any type of material. Simple flyer arms at lower cost are available for “easy” material; please contact us for details.